

INSTALLATION AND MAINTENANCE

Installation of MDB-N Brakes

The unit consists of four major components: the field, the rotor/hub assembly, the armature and the multiple friction disks. When the current is applied to the coil, the armature is pulled in, compressing the multiple disks and the friction between the disks functions as brake.

Installation Procedure

1. Mount the field to the machine frame using the four tapped holes provided. Concentricity of the field with the shaft should be less than 0.008" TIR. The perpendicularity of the field at the mounting surface should be less than 0.004" TIR.
2. Next, the rotor hub assembly should be slid onto the shaft and a spacer (customer supplied) needs to be provided to set the proper distance to align the rotor/hub. Mount the rotor/hub assembly so that the dimension shown with * is as specified in the table 1 (+/- 0.0012"). When the rotor/hub assembly is mounted at the correct position, 6 out stoppers (tang) from the field OD and the armature contact surface are aligned as shown with the arrow.
3. Once the proper alignment is achieved the inner rotor hub assembly should be held in place via a set collar or other locking mechanism.

Table 1

Model	1.2N	2.5N	5N	10N	20N	40N	80N
Dimension [inch]	0.669	0.709	0.827	0.669	0.709	0.551	0.551

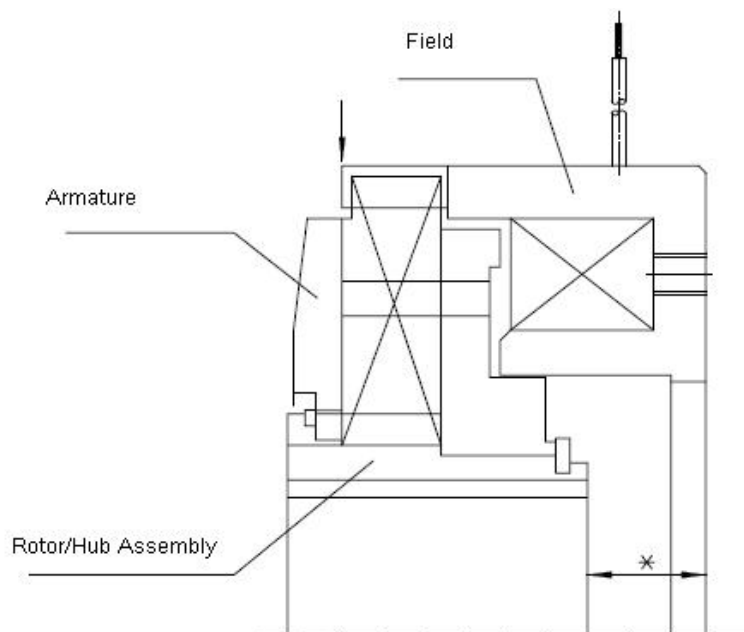

Maintenance

The friction disks on this unit wear due to slippage at the engagement, increasing the release. Although this unit does not require adjustments to the gap between the disks, when the release amount reaches the max, it affects the pull-in time. Replacing the friction disks is recommended.

1. Torque of this unit is determined by the voltage. Periodically, it should be checked if the specified voltage is supplied to the unit (When a long wire is used, the voltage at the unit can be lower than the voltage at the power supply).

