INSTALLATION AND MAINTENANCE

Installation of MNB Brakes

Installation Procedure

1. The complete unit consists of two major subassemblies: the brake body, which includes the armature and friction disk, and the hub.
2. The mounting surface of the brake cover plate should be perpendicular to the shaft within 0.002” TIR for MNB 0.2~5 and 0.004” TIR for MNB 10~80. The pilot and bolt circle should be concentric to the shaft within 0.008” TIR for MNB 0.2~5 and 0.012” TIR for MNB 10~80.
3. Slide the hub onto the shaft and install the key. For an inside hub mount, the distance between the mounting surface of the brake cover plate and the top of the hub should match dimension P1 specified on the MNB data sheet. For an outside hub mount, use dimension P2. Then tighten the set screws.
4. Slide the brake body onto the shaft over the hub, matching the friction disk spline to the hub spline.
5. Insert the mounting bolts through the brake into the tapped holes on the wall of the machine or support bracket. If all holes line up, bolt the brake in place. If the holes are not aligned, energize the brake coil to release the friction disk. Then align the holes and bolt the brake in place.
6. Cycle the brake under normal loading conditions. If any noise from contact is noticed, make sure the hub is not hitting the armature and verify proper mounting.

Manual Release

All models have two or three tapped holes on the brake cover plate. These brakes can be manually released by inserting the appropriate metric screws specified on the MNB data sheet. Alternately tighten the screws to release the brake. Take care not to overtighten the screws beyond the point where the armature contacts the field, as this will damage the unit.

Torque Adjustment

The brake torque can be adjusted on all models by varying the spring pressure. First, loosen the lock nuts on the torque adjustment bolts. Then tighten or loosen the adjustment bolts/nuts to change the brake torque as desired. Refer to table 1 for a correlation between torque and

“What you need in a clutch”[®]

bolt/nut position. Note that the referenced torque values are for a new unit. As the brake wears in, these values will change accordingly. Once the adjustment bolts/nuts are in position, tighten the lock nuts to lock them in place.

Table 1-A

Model		0.2	0.4	0.8
Torque [Nm]	A [mm]	15.5	2	4
		16	1.6	3.2
		16.5	1.2	2.4
		20.5		
		20.9		
		21.3		
				8
				6.4
				4.8

Table 1-B

Model		1.2	2.5	5	10	20	40	80	
Torque [Nm]	A [mm]	5	12						
		6	9.5	25	50	100			
		7	7						
		8		20	40	80	200		
		10		15	30	60	160		
		12					120		
		14						400	800
		16						350	
		17							700
		18						300	
		20							600

Maintenance

Under normal usage, these brakes do not require any maintenance. However, all models can be adjusted for wear. To reset the gap, loosen the inner adjustment nuts on the field flange. Tighten the outer nuts until the proper gap is set. Then tighten the inner nuts against the flange to set the gap. Make sure that the air gap measured at all three of these points is within 0.05mm of each other. Table 2 shows the maximum allowable gap before adjustment is required, the specified range to which the gap should be adjusted, and the nut size.

Table 2

Model	0.2	0.4	0.8	1.2	2.5	5	10	20	40	80
Max Gap [mm]	0.6			0.8				1.0	1.2	
Adjustment Range [mm]	0.1~0.3						0.2~0.4			0.3~0.5
Nut Size	M4	M5		M6		M8		M10	M12	M16

“What you need in a clutch”[®]

Contamination

These units are to be used in dry environments only. Contaminants such as oil and grease should not be permitted to contact the friction surface at any time. If the friction material becomes contaminated, the brake will probably need to be replaced. Do not attempt to disassemble the unit. The spring is under high compression and can cause harm if it is released.

Initial Torque

Out-of-box torque of these units is approximately 70% of the rated torque (requires burnishing for units to achieve rated torque).

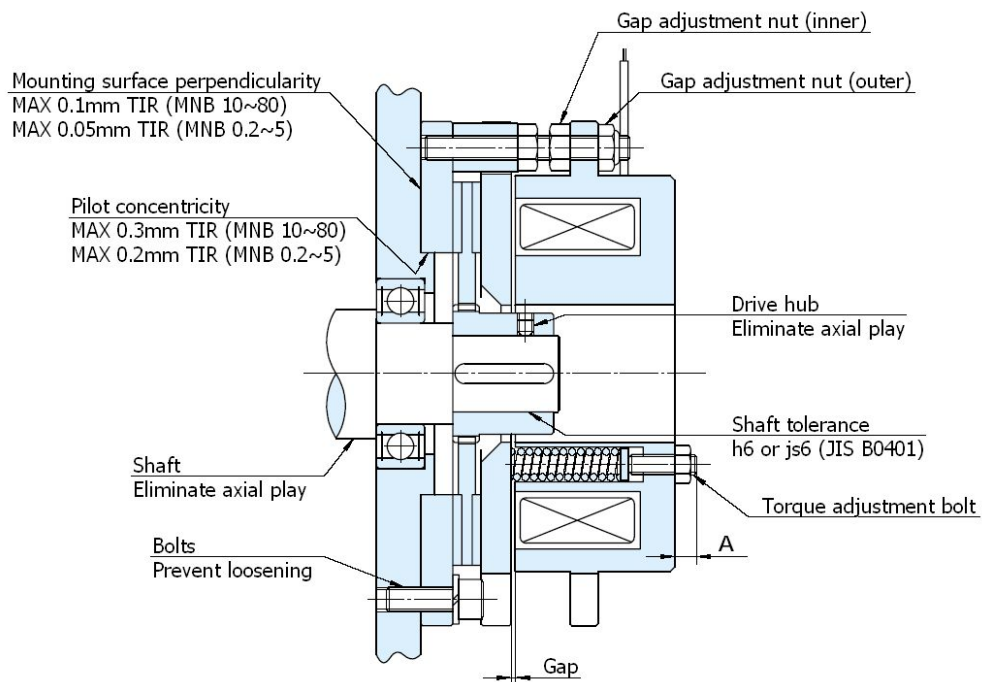

MNB 1.2~80

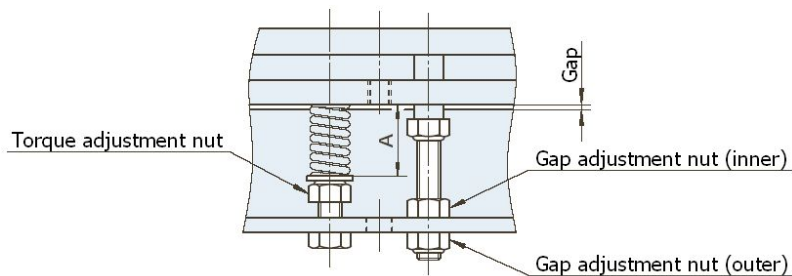

MNB 0.2~0.8