INSTALLATION AND MAINTENANCE

Installation of HC Clutches

Installation Procedure

1. The unit comes completely assembled, and there are no gaps to set. The unit can be mounted in the horizontal or vertical position.
2. The unit is normally custom-fitted to a customer's machine. The support bracket manufactured by the customer is required to hold the unit in place. For mounting purposes, all models have bearing support for both input and output shafts.
3. The support bracket should be perpendicular to the shaft within 0.004" TIR. The bearing pilots and bolt circle should be concentric to the shaft within 0.004" TIR.
4. The bearing holding the output assembly should be restrained via a snap ring or end cap. Connections to the output shaft should be via a belt or flexible coupling to avoid overstressing the internal bearings. Couplings should allow for both axial and radial misalignment. Care should be taken not to exceed bearing load limitations.
5. Connect the lead wires to the power source. The brake torque can be adjusted by varying input current. Torque is approximately linearly proportionate to current for the majority of the unit's torque range.

Maintenance

Since there is no contact between the rotating clutch components, these units have extremely long life, which is normally limited only by bearing life. Bearing life is a function of speed and loading conditions, thus can be estimated if these parameters are specified.

There is a possibility for particles to be attracted to the armature since it is a permanent magnet. If noise or drag is noticed when there is no power applied, particles may be trapped in the armature. To remove these particles, try using a stronger exterior magnet to pull them out or compressed air to dislodge them.

Residual magnetism may remain in the permanent-magnet hysteresis disk when switching from high to low input current or when cutting power at low slip speeds (below 50rpm). This will cause a cogging effect (~10% rippling torque) at the lower torque value or when restarting. To dissipate any residual magnetism, rotate the unit while gradually decreasing input current.

"What you need in a clutch"®

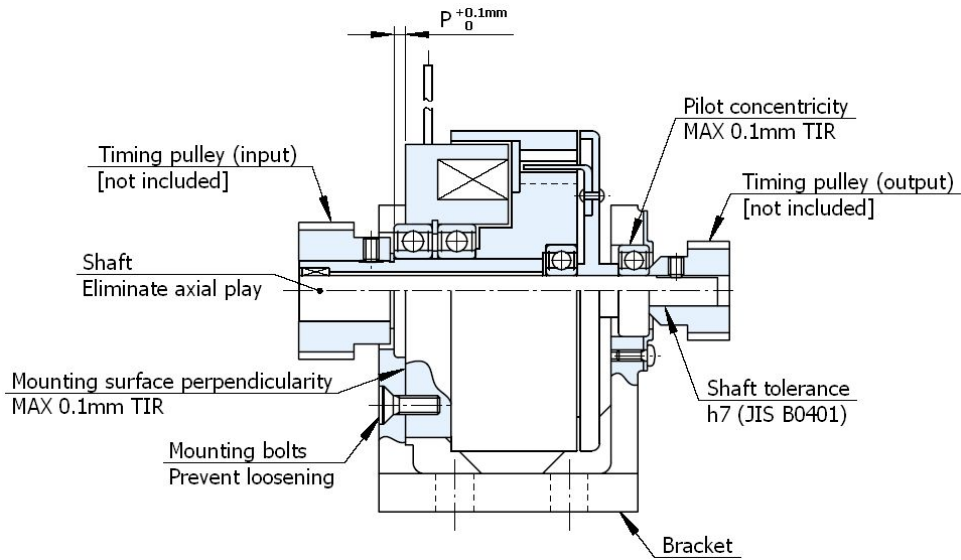

Heat Dissipation

Here is a quick reference for determining slip watts for slip applications (Hysteresis clutches/brakes are normally limited by heat dissipation rather than by torque when they are involved in a constant slip application).

$$W = .0118 \times T \times \Delta \text{ rpm}$$

W: watts

T: torque [in-lbs]

Δ rpm: Speed difference between input and output